

(12) UK Patent Application (19) GB (11) 2 267 392 (13) A

(43) Date of A publication 01.12.1993

(21) Application No 9311124.3

(22) Date of filing 28.05.1993

(30) Priority data

(31) 9211265 (32) 28.05.1992 (33) GB

(71) Applicant

Philip Collins
2 Rutherford Court, 15 North Avenue, Clydebank
Business Park, Clydebank, Glasgow, G81 2QP, United
Kingdom

(72) Inventor

Philip Collins

(74) Agent and/or Address for Service

Cruikshank & Fairweather
19 Royal Exchange Square, Glasgow, G1 3AE,
United Kingdom

(51) INT CL⁵
H01C 10/10

(52) UK CL (Edition L)
H1S SBH S12 S6A3 S9A3 S9E4
U1S S2116

(56) Documents cited

GB 2222029 A GB 2088063 A GB 1322218 A
GB 0827987 A EP 0353127 A EP 0284787 A

(58) Field of search

UK CL (Edition L) H1S SBH SBK SBX
INT CL⁵ H01C
On-line databases: WPI

(54) Pressure-sensitive variable resistor with slidably moving member

(57) A variable resistor (10) comprises: a resistive material (12) e.g. of conductive plastics on a first member (14) e.g. a printed circuit board; at least one membranous layer (e.g. polycarbonate) (16) carrying a conductive area 32 and enclosing the resistive material (12); and a slidably movable member (22) having a contact member (22) which exerts a force on the membranous layer (16) to contact a portion of the conductive area 32 with the resistive material 12. The resistor is used in a linear fader for controlling recording levels.

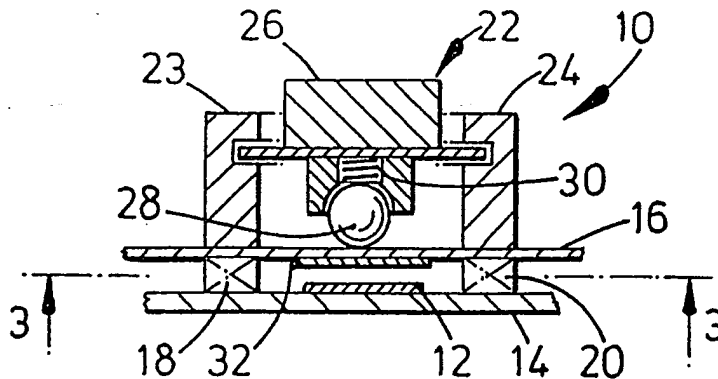

FIG. 1

At least one drawing originally filed was informal and the print reproduced here is taken from a later filed formal copy.

This print takes account of replacement documents submitted after the date of filing to enable the application to comply with the formal requirements of the Patents Rules 1990.

GB 2 267 392 A

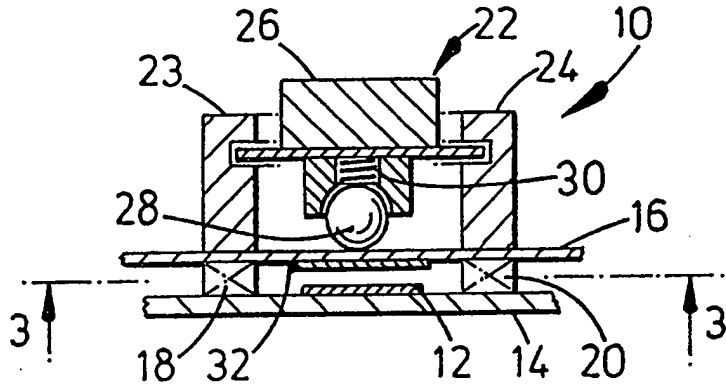

FIG. 1

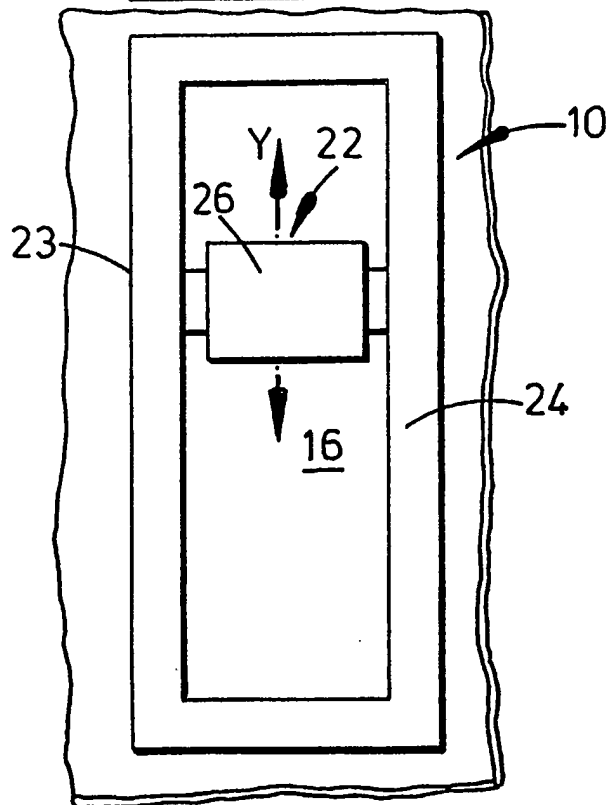

FIG. 2

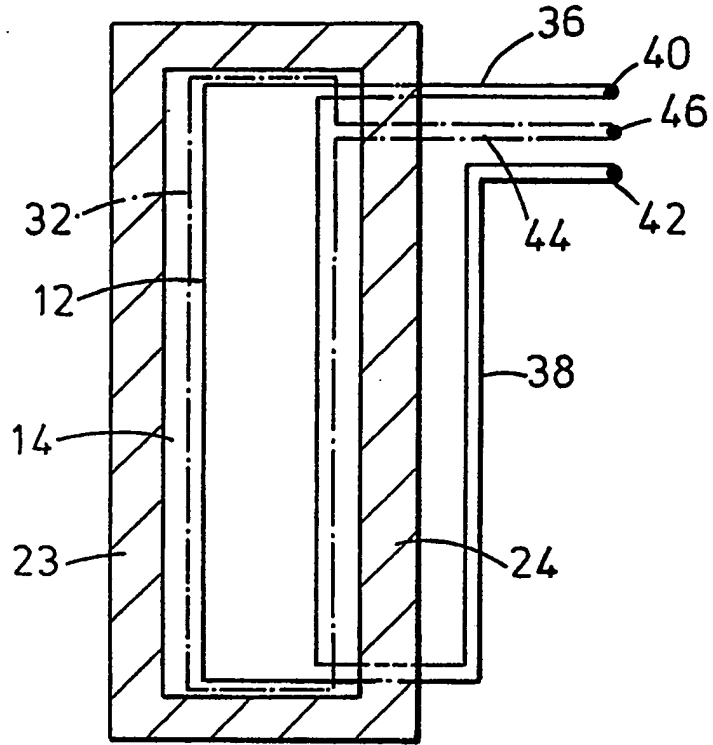

FIG. 3



FIG. 4a



FIG. 4b

VARIABLE RESISTOR

This invention relates to a variable resistor, and in particular, but not exclusively to a variable resistor for use in a linear fader.

Variable resistors or rheostats are well known electrical components which enable a resistance to be readily varied. The variation may be controlled manually by a knob or handle controlling rotation of a shaft or the position of a slider, or by means such as an electric motor.

In recording studios, recording levels are typically controlled from a desk or console which includes a large number of slider operated faders, each fader incorporating a variable resistor. The upper face of the console is slotted to permit movement of the sliders, and these slots allow dust and other substances, such as spilled drinks, to enter the console and affect the operation of the resistors.

Use of membranes to protect such resistors is known, as disclosed in GB2222029, and which describes a potentiometer in which a track of conductive material carried by a flexible substrate may be brought into contact with a track of electrically resistive material by applying pressure to the upper surface of the flexible substrate. On release of the pressure the contact

position is retained by use of an appropriate memory arrangement. This permits the tracks to be sealed against dust and moisture, however, there is no direct visual indication of the potentiometer setting, and with this arrangement it would be most difficult to progressively increase or decrease the settings of a plurality of adjacent potentiometers.

According to the present invention there is provided a variable resistor comprising: a resistive material on a first member; at least one membranous layer enclosing the resistive material; and a slidably movable member having a contact member which exerts a force on the resistive material through the membranous layer.

Preferably, the resistive material is in the form of an elongate layer or strip along the length of which the slidably movable member is movable. The layer may be of constant cross-section along its length, that is rectangular, or may of variable profile, for example wedge-shaped. A constant cross-section layer provides a resistance which is directly proportional to the contact member position, while a layer of variable profile provides a non-linear output following, for example, a logarithmic, antilogarithmic or sine wave pattern.

Preferably, the resistive material is a conductive plastics material although other resistive material, such as a wire winding, could be used.

Preferably, the first member is a printed circuit

board to which the resistive material is bonded.

Preferably, the membranous layer is sealed to the first member, enclosing the resistive material, and carries an area of conductive material corresponding to the resistive material, a portion of which conductive material contacts the resistive material when the contact member exerts a force on a portion of the membranous layer.

There may be a further transparent or translucent membranous member in order to allow a graphic overlay to be provided thereunder.

Preferably, the membranous layer is formed of a polycarbonate or polyester material, although other suitable materials may be used.

Preferably, the slidably movable member is in the form of a trolley or carriage with support members which run along either side of the resistant material layer and having a handle for manual control of the slidably movable member. This arrangement permits application of simple vertical thrust to the contact member, providing greater reliability and a relatively compact arrangement.

The contact member may be in the form of a roller, with a contact area corresponding to the length of the roller which extends transversely across the resistive layer; alternatively, the contact member may be in the form of a ball-bearing which runs along the resistive material. Alternatively, the contact member may provide a sliding rather than a rolling surface.

Each time the contact member exerts a force on the resistive material or is run along the resistive material from a datum or zeroed position the contact or run may be counted. This is useful in determining when a particular resistor is likely to require replacement or repair, as testing or prolonged use will allow an estimation of the number of operations which a resistor is subject to before the likelihood of failure rises to an unacceptable level. Monitoring the counter thus allows replacement of resistors at appropriate times and avoids the likelihood of a resistor failure while the resistor is in use, as such a failure could lead to inconvenience and incur considerable expense.

Preferably, an indicator light indicates when the resistive material is nearing said predetermined number of operations and is required to be replaced.

The indicator light may be in the form of a light emitting diode or other light emitter.

Preferably, the variable resistor can be used to control external equipment.

Preferably, a plurality of resistors may be provided and arranged to permit simultaneous manual operation.

Embodiments of the present invention will now be described with reference to the accompanying drawings in which:

Figure 1 is a somewhat schematic cross-sectional view of a variable resistor in accordance with one embodiment

of the present invention;

Figure 2 is a plan view of the variable resistor of Figure 1;

Figure 3 is a sectional view on line 3-3 of Figure 1;

Figure 4a and 4b are plan views of layers of resistive material of variable resistors in accordance with further embodiments of the present invention.

Referring firstly to Figures 1, 2, and 3 of the drawings, there is shown a variable resistor such as provided in a recording studio control console, and which is commonly known as a "fader". The variable resistor 10 has a resistive material in the form of a rectangular strip 12 carried by a first member in the form of a printed circuit board (PCB) 14. A membranous layer 16 is sealed to the PCB via spacers 18, 20, and encloses the resistive strip 12. A transparent second membranous layer (not shown) may be placed above the membranous layer 16, on which appropriate graphic illustrations may be printed.

The slidably movable member is in the form of a trolley or carriage 22 with support rails 23, 24, a control handle 26 and a contact member in the form of a ball-bearing 28, biased downwardly by a spring 30.

The membranous layer 16 carries a conductive strip or wiper corresponding to the resistive strip 12 and formed of a material suitable to contact the strip 12. The trolley 22 slides above the membranous layer 16 with the support rails 23, 24 resting on either side of the

resistive strip 12. The ball-bearing 28 exerts a downward vertical thrust on the strip 32, via the layer 16, forcing a contact between the resistive strip 12 and the conductive strip 32.

The form of the resistive strip 12 is illustrated in solid outline in Figure 3 of the drawings. The strip has a predetermined end-to-end resistance and is provided with low resistivity connectors 36, 38 which extend from the ends of the strips 12 to contacts 40, 42. The conductive strip 32 is shown in chain dotted outline in Figure 3 and has a single connector 44 and associated contact 46.

At the point of contact between the strips 12, 32 a circuit is formed and the resistance between the contact 46 and the contacts 40, 42 will be a function of the position of the point of contact along the strip 12. Thus, as the carriage is moved in direction Y, the resistance between the contacts 46, 40, 42 will also vary. The value of resistance corresponding to a particular wiper position may be indicated by a scale printed on or to the side of the rails. The carriage 22 and the rails 23, 24 are formed of nylon, ABS or a similar low-friction material, to facilitate movement of the carriage. However, the upward force provided by the spring 30 is sufficient to hold the carriage in a desired location relative to the rails.

Further, in alternative arrangement, by applying a fixed DC voltage across the lower strip 12, the upper

strip or wiper 32 will sense a voltage, measured from either end of the strip 12, proportional to the position of the wiper 32. This voltage may be applied to an external voltage controlled device, such as a amplifier, attenuator, resistor and the like.

From the above description it will be noted that the disclosed fader provides a relatively straightforward arrangement in which the strips 12, 32 are sealed against ingress by dust and moisture. The fader is compact and thus a plurality of faders may be located in a console in such a manner that an operator can move and thus adjust a number of faders simultaneously, the positions of the carriages relative to the rails providing an immediate visual indication of the fader setting.

While the above described embodiment features a rectangular resistive strip 12, it is also possible to provide strips of variable profile, such as the strips 50, 52 illustrated in Figures 4a and 4b of the drawings. This provides or a non-linear relationship between carriage or wiper position and resistance. Such a relationship of course relies on the material which forms the strips 50, 52 having a uniform longitudinal resistance for a given, fixed width. Also, the conductive strip for such a resistor should be at least as wide as the widest point of the strip 50, 52.

As such resistors and faders are used, the strips will wear and at some point will reach a condition where

replacement is required. Accordingly, the fader is provided with a counter which, for example, counts down from a predetermined number each time the fader is used. The counter may be activated each time the fader is 'zeroed', as is common practise at the end of a typical recording session. The counter may be linked to, for example, a voltage monitor which produces a signal when the voltage measured across the contacts passes a predetermined value.

On the counter reaching the predetermined count an indicator, typically an LED located adjacent the fader, is activated. The operator may then replace the strips 12, 32 the reliability of the fader is maintained.

It will be clear to those of skill in the art that the abovedescribed embodiment is merely exemplary of the present invention and that various modifications and improvements may be made thereto without departing from the scope of the invention, for example: the ball-bearing described above may be replaced by a simple non-rolling slider, or by a roller bearing which exerts pressure across the width of the strip 32.

CLAIMS

1. A variable resistor comprising: a resistive material on a first member; at least one membranous layer enclosing the resistive material; and a slidably movable member having a contact member which exerts a force on the resistive material through the membranous layer.
2. The resistor of claim 1 wherein the resistive material is in the form of an elongate layer or strip along the length of which the slidably movable member is movable.
3. The resistor of claim 1 wherein the layer is of constant cross-section along its length.
4. The resistor of claim 2 wherein the layer is of variable profile along its length.
5. The resistor of any one of the preceding claims wherein the resistive material is a conductive plastics material
6. The resistor of any one of the preceding claims wherein the first member is a printed circuit board to which the resistive material is bonded.

- 10 -

7. The resistor of any of the preceding claims wherein the membranous layer is sealed to the first member, enclosing the resistive material, and carries an area of conductive material corresponding to the resistive material, a portion of which conductive material contacts the resistive material when the contact member exerts a force on a portion of the membranous layer.

8. The resistor of any one of the preceding claims wherein the membranous layer is formed of a polycarbonate or polyester material.

9. The resistor of any one of the preceding claims wherein the slidably movable member is in the form of a trolley or carriage with support members which run along either side of the resistant material layer and having a handle for manual control of the slidably movable member.

10. The resistor of any one of the preceding claims wherein the contact member is in the form of a roller, with a contact area corresponding to the length of the roller which extends transversely across the resistive layer.

11. The resistor of any one of claims 1 to 9 wherein the contact member is in the form of a ball-bearing which runs along the resistive material.

12. The resistor of any one of the preceding claims further including a counter, the arrangement being such that each time the contact member exerts a force on the resistive material or is run along the resistive material from a datum or zeroed position the contact or run is counted.

13. The resistor of claim 12 wherein an indicator light indicates when the resistive material is nearing a predetermined number of contacts or runs.

14. The resistor of claim 13 wherein the indicator light is in the form of a light emitting diode.

15. The resistor of any one of the preceding claims wherein a plurality of resisters are provided and arranged to permit simultaneous manual operation thereof.

16. A resistor substantially as described herein and as illustrated in Figures 1, 2 and 3, or Figure 4a, or Figure 4b of the accompanying drawings.